

PRODUCT DATA SHEET**■ MAC10[®] LEAC2 Introduction**
Extra low watts, sound, and profile

The ENVIRCO[®] LEAC2 fan filter unit is the first (FFU) with low watts, low profile, and high airflow. The MAC 10[®] LEAC2 2x4 ft (600x1210 mm) provides one of the lowest power consumption levels of any FFU in the industry. Running at only 208 watts @ 90 fpm, the unit uses less energy than traditional FFUs and reduces operating costs. The MAC 10[®] LEAC2 standard model maintains a low profile, measuring less than 13" (318 mm) tall. The MAC 10[®] LEAC2 comes standard with the filter integral with the unit housing. Room-side replaceable filters and motor blower removable from room-side are available.

**ENVIRCO Performance and Innovation**

The LEAC2 comes standard with a solid-state speed control and will operate against high external static pressure to provide superior filter life. By taking advantage of a unique combination of motor blower technology, along with ENVIRCO's proprietary baffling system, the LEAC2 delivers uniform airflow over a wide range of cfm.

ENVIRCO[®] MAC 10[®] FFUs are used worldwide for a variety of critical clean air applications. Learn more about how you can benefit from the LEAC2 in your next critical room application. Contact your local ENVIRCO[®] representative or visit us on the web at www.envirco.com.

■ Standard Features

- » Low watts, low profile, and low operating costs
- » Solid State Speed Control - 3 speed switch is not available (see LEAC 2x4 only)
- » Integrated PSC Motorized Backward Inclined Impeller
- » High Efficiency Particulate Air (HEPA) Filter: 99.99% efficient @ 0.3 micron
- » 1.0 in. wg (200 Pa) of external static capability
- » Walkable plenum (excluding prefilter), rated to 250 lbs.
- » Snap-in 20 x 20 washable pre-filter
- » Manufactured to IEST recommended practices; IEST-RP-CC036.1
- » Available in 2x2, 2x3, and 2x4 sizes
- » cUL listed (115V, 277V) with standard UL 900 filter, file number E152685 (UL507)
- » Mill finished aluminum exterior
- » Aluminum Diffuser Screen (RSRE)
- » Room-side Challenge Ports standard on RSRE
- » Room-side Replaceable Filter and Motor Assembly standard on RSRE

■ Optional Features

- » Modbus Equipped Variable Speed Control Card (ENAC) compatible with ENVIRCO control systems
- » Direct connection to air conditioning supply
- » Ducted Inlet Connection (shipped loose)
 - 10" (254 mm)
 - 12" (305 mm)
 - 14" (356 mm)
- » Airflow indicator light: Allows external monitoring of motor operation; green indicator is ON during normal operation
- » Filter Load Indicator Light
- » Pressure Transducer for continuous filter monitoring
- » Flow-through light fixture provides illumination with minimal airflow disruption
- » Powder coat white paint or stainless steel housing
- » Room-side 3/8" Challenge Ports: convenient aerosol challenge and HEPA filter testing
- » ULPA 99.9995% at 0.12 micron PTFE and low boron
- » 3/4" Knife Edge: Permits easy placement in gel track ceiling grid system (available on RSRE units only)
- » MERV 8 pre-filter available
- » Stainless Steel Diffuser Screen

MAC 10[®] LEAC2

Fan Filter Unit



PRODUCT DATA SHEET

■ Dimensions

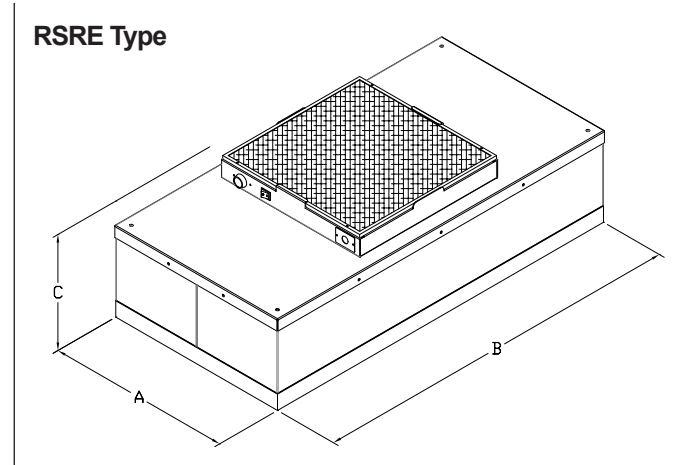
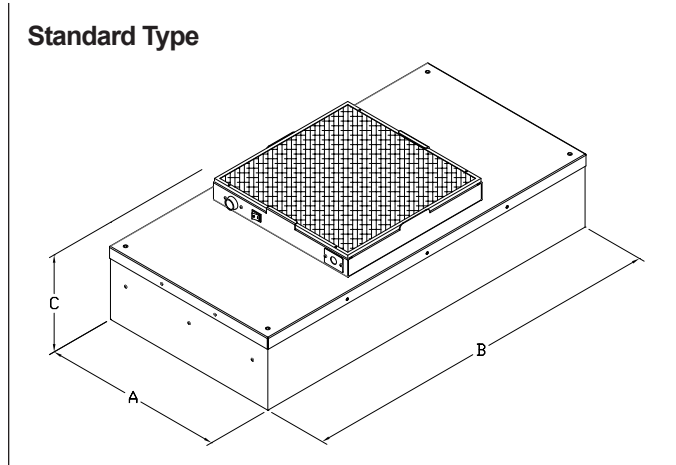

■ Performance MAC 10[®] LEAC2

Nominal Unit Size	Active Filter Face Area (Sq. Ft.)	Max. CFM	Watts @ Max. CFM	CFM @ 90 FPM	Watts @ 90 FPM	Unit Weight**	Dimensions AxBxC (in)
2x4 LEAC2	7.2	800	192	650	208	50	23.63 x 47.63 x 12.375 (600 x 1210 x 318)
2x3 LEAC2	5.3	758	196	470	201	42	23.63 x 35.63 x 12.375 (600 x 905 x 318)
2x2* LEAC2	3.5	670	201	315	178	35	23.63 x 23.63 x 12.375 (600 x 600 x 318)
2x4 LEAC2 RSRE	5.3	750	192	477	204	61	23.63 x 47.63 x 14.61 (600 x 1210 x 371)
2x3 LEAC2 RSRE	3.8	687	198	340	189	53	23.63 x 35.63 x 14.61 (600 x 905 x 371)
2x2* LEAC2 RSRE	2.3	555	198	210	160	42	23.63 x 23.63 x 14.61 (600 x 600 x 371)

* Do not operate 2x2 units above 400 SCFM. Damage to the filter and/or particle bleed-through can occur.

**Add approximately 10 lbs. for Stainless Steel exterior

Notes:

Performance tested in accordance with the (ANSI/AMCA 210-07), (ANSI/ASHRAE 51-07) test standards for Certified Aerodynamic Performance Rating.

Max CFM rating based on free air volumes @ high speed motor setting.

90 fpm values based on active filter face area. BTU = Watts x 3.413.

MAC 10[®] LEAC2:

MAC 10[®] LEAC2 115V, 50/60HZ 1 Phase = 1.8 F.L.A., 277V 60 HZ 1 Phase = .80 F.L.A.